



ALCM-MB

Micro-Bend Coriolis Mass Flowmeter

Model ALCM Series

GENERAL

SMARTMEASUREMENT's ALCM-MB Micro-Bend Coriolis Mass flowmeter employs a unique tube arrangement with U-shaped measuring tubes that are formed with a significantly smaller radius versus traditional U-tube type Coriolis meters. The more gradual radius of the ALCM-MB's tube geometry provides for a more compact design and significantly reduced pressure differential versus other Coriolis meters.

The ALCM-MB features an easy-to-read color OLED display that can be configured to display either mass or volumetric flow rates in a variety of user-selectable engineering units as well as density, temperature, and totalized flows. This meter offers excellent value by providing a highly accurate, compact instrument that can measure flow, density, and temperature in a single package that has lower cost, lower pressure differential and a more compact design versus competitive Coriolis-technology flowmeters. The unique combination of features and benefits offered by the ALCM-MB make it an ideal choice for applications that are found in a variety of industries including Food & Beverage, Petrochem, Oil & Gas, Paint, and Industrial Process Control.



FEATURES

- Suitable for aggressive and contaminated media
- Measurement of mass flow, density, temperature and volume flow
- High rotation frequency and well-balanced measuring tubes
- Excellent purging and sterilization qualities due to a construction free of dead spots
- Operation up to+ 662°F (350°C)
- Individual 8-point-calibration including report
- PT100 Temperature Sensor Included
- EX protection (optional)

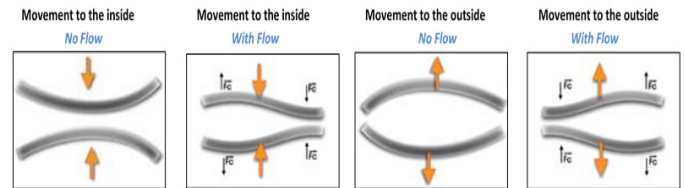

SPECIFICATIONS

- | | | | |
|--------------------------|---|-------------------------|--|
| • Flow Range: | 88~5,500,00lb/hr.
(40~2,500,000 kg/hr.) | • Process Temperature: | -58~662°F (-50~350°C) |
| • Line Sizes: | ¼"~12" (8-300 mm) | • Ambient Temperature: | -5~312°F (-20~55°C) |
| • Process Connections: | Flanged (ANSI, DIN, Tri-Clamp®) | • Max Working Pressure: | 3600 psig (25MPa) |
| • Tube geometry: | U-Tube with Micro Bend | • Measuring Tube Mat'l: | SS per DIN1.4571 (AISI 316Ti) (std) |
| • Accuracy: | ±0.5% of reading (std),
0.2% or 0.1% (opt) | • Housing Material: | SS #304 |
| • Repeatability: | ±0.075% of reading | • Power Supply: | 24 V _{DC} , ± 20%; 86~260V _{AC} , 50~60Hz |
| • Frequency: | 10-2000 Hz | • Power Consumption: | Less than 6W |
| • Display: | Color Graphic OLED | • Outputs: | 4-20 mA, 0-10 kHz pulse, RS485 |
| Eng. Units (Mass): | kg, lb, ton, etc. | • Density Meas. Range: | 12.5-125lb/ft ³ (0.2~2.0 g/cc) |
| Eng. Units (Temp): | °C, °F | • Density Accuracy: | ±0.06 lb/ft ³ (0.001 g/cc) |
| Eng. Units (Vol.): | m ³ , Liter, US Gallon/
Imperial Gallon, etc. | • Temperature Accuracy: | up to ±1°F (°C) |
| • Zero Drift (%FS / °C): | 0.005 | • Water Cut Accuracy: | ±0.1% of range |
| | | • Approval: | UL/CUL/CSA Class I, Div 1 & 2, Groups B, C & D  |

REV0622

METER SIZE INCHES (MM)	FLOW RANGE LB./HR. (KG/HR.) (0.2% & 0.5% ACCURACY)	FLOW RANGE LB./HR. (KG/HR.) ACCURACY 0.15%	STABILITY OF ZERO POINT LB./HR. (KG/HR.)
¼" (8)	88~1,763 (40~800)	176~1,763 (80~800)	0.17 (0.08)
⅜" (10)	110~2,204 (50~1,000)	220~2,204 (100~1,000)	0.22 (0.1)
½" (15)	220~6,130 (100~3,000)	440~6,130 (200~3,000)	0.44 (0.2)
1" (25)	661~17,630 (300~8,000)	1,322~17,630 (600~8,000)	1.32 (0.6)
1½" (40)	2,024~52,910 (1,000~24,000)	5,290~52,910 (2,400~24,000)	5.29 (2.4)
2" (50)	4,409~110,231 (2,000~50,000)	11,023~110,231 (5,000~50,000)	11 (5)
3" (80)	13,227~265,000 (6,000~120,000)	17,637~265,000 (8,000~120,000)	17 (8)
4" (100)	22,400~440,924 (10,000~200,000)	33,069~440,924 (15,000~200,000)	33 (15)
6" (150)	55,115~1,102,311 (25,000~500,000)	110,231~1,102,311 (50,000~500,000)	110 (50)
8" (200)	110,231~2,204,623 (50,000~1,000,000)	220,462~2,204,623 (100,000~1,000,000)	220 (100)
10 (250)	165,346~3,306,900 (75,000~1,500,000)	330,690~3,306,900 (150,000~1,500,000)	330 (150)
12" (300)	204,623~5,511,556 (100,000~2,500,000)	440,924~5,511,556 (200,000~2,500,000)	440 (200)

Accuracy

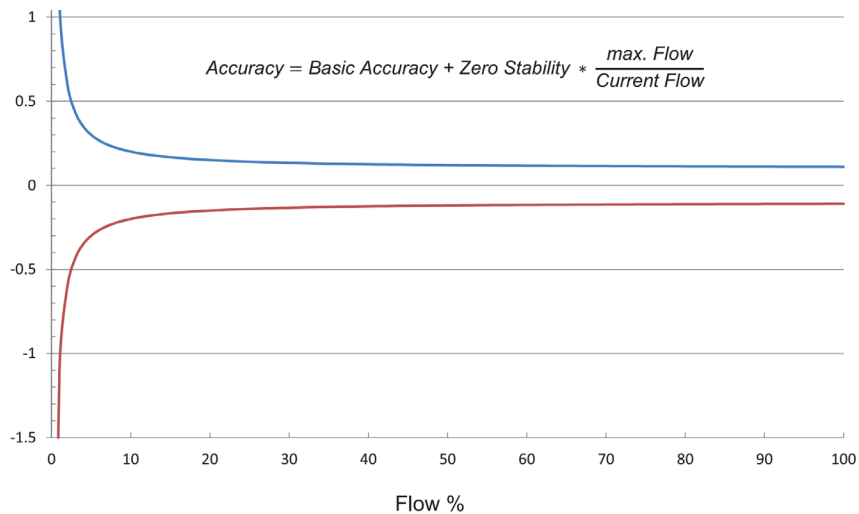

This diagram shows typical values. Individual values may be taken from the calibration records supplied with each meter.

Repeatability

ACCURACY	0.15%	0.20%	0.50%
REPEATABILITY	±0.05%	±0.1%	±0.25%

Accuracy is calculated based on the water measurement under the condition of +20°C ~ 25°C and 0.1MPa ~ 0.2MPa.

Density Measuring

DENSITY RANGE	12.5-125lb/ft ³ (0.2~2.0 g/cc)
BASIC ERROR	±0.06% lb/ft ³ (0.001 g/cc) Affected by the transducer
REPEATABILITY	±0.06% lb/ft ³ (0.001 g/cm ³)

DIMENSIONS

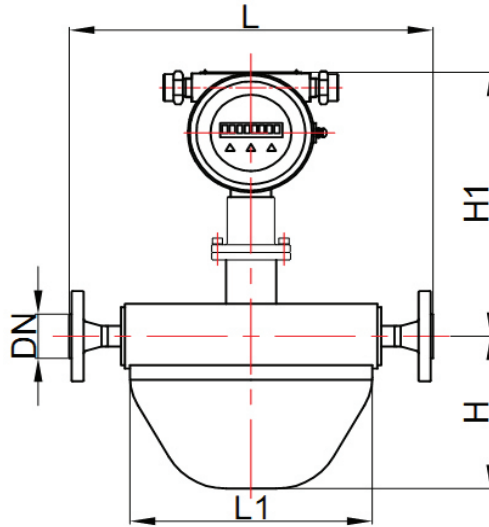

-All dimensions in units of inches (mm)-

NOMINAL LINE SIZE	L INCHES (MM)	L1 INCHES (MM)	H INCHES (MM)	H1 INCHES (MM)	TOLERANCE INCHES (MM)	WEIGHTS LB. (KG)
¼" (8)	16.69 (424)	13.93 (354)	6.06 (154)	11.02 (280)	± 0.06 (1.5)	17.6 (8)
⅜" (10)	16.69 (424)	13.93 (354)	6.06 (154)	11.02 (280)		17.6 (8)
½" (15)	15.74 (400)	11.02 (280)	7.24 (184)	11.41 (290)		26.4 (12)
1" (25)	19.68 (500)	14.17 (360)	9.84 (250)	11.81 (300)	± 0.1 (2.5)	33.1 (15)
1½" (40)	23.62 (600)	18.11 (460)	11.81 (300)	12.20 (310)		55.1 (25)
2" (50)	31.49 (800)	25.19 (640)	16.14 (410)	12.59 (320)		83.8 (38)
3" (80)	35.43 (900)	27.55 (700)	19.29 (490)	13.77 (350)		171.9 (78)
4" (100)	44.48 (1130)	33.85 (860)	25.98 (660)	14.56 (370)	± 0.14 (3.5)	297.6 (135)
6" (150)	57.08 (1450)	47.24 (1200)	35.43 (900)	15.74 (400)		584.2 (265)
8" (200)	70.86 (1800)	57.08 (1450)	46.06 (1170)	16.53 (420)		947.9 (430)
10" (250)	72.83 (1850)	60.23 (1530)	46.45 (1180)	16.53 (420)		1102.3 (500)
12" (300)	78.74 (2000)	62.99 (1600)	51.18 (1300)	18.11 (460)		1388.9 (630)

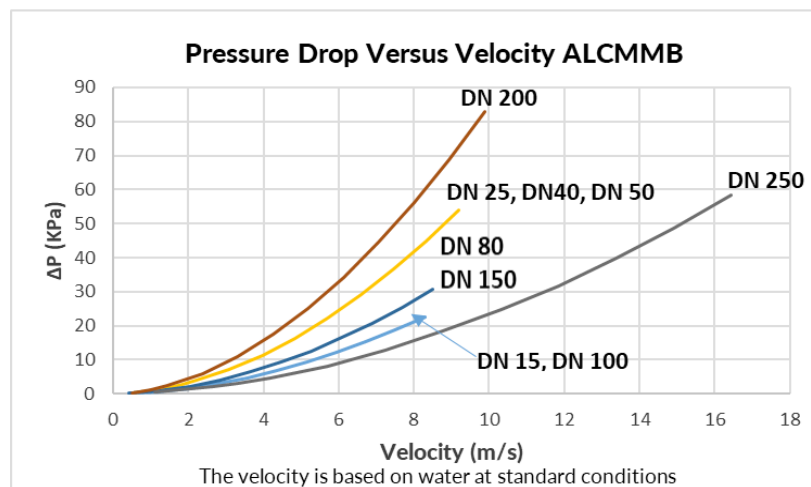

TYPE OF FLUID	Please provide the name of your fluid, including operating density and viscosity
FULL-SCALE FLOW RATE	Please provide the max and min flow rate, normal flow rate also
LINE SIZE	Please provide the line size and connection
PROCESS PRESSURE & TEMPERATURE	We will calibrate your flow meter as close to your operating conditions as possible
PRESSURE DROP	Please indicate the maximum allowable pressure drop
TYPE OF ELECTRONICS	Please specify output and installation type (wall mount, panel mount, etc.)
POWER REQUIREMENTS	Please specify AC or DC power supply

ALCM-MB SERIES

EXAMPLE 1: ALCM-MB-25F-5-1-1-CYS-NX-DC-NN

ALCM-MB	**	**	**	**	**	**	**	**	**	**	DESCRIPTION
¼" (8 mm) 88~1,763 Lb/hr (40~800 kg/hr)	8										Nominal Line Size
⅜" (10 mm) 110~2,204 Lb/hr (50~1000 kg/hr)	10										
½" (15 mm) 220~6130 Lb/hr (100~3,000 kg/hr)	15										
1" (25 mm) 661~17,630 Lb/hr (300~8,000 kg/hr)	25										
1½" (40 mm) 2,204~52,910 Lb/hr (1,000~24,000 kg/hr)	40										
2" (50 mm) 4,409~110,231 Lb/hr (2,000~50,000 kg/hr)	50										
3" (80 mm) 13,227~265,000 Lb/hr (6,000~120,000 kg/hr)	80										
4" (100 mm) 22,400~440,924 Lb/hr (10,000~200,000 kg/hr)	100										
6" (150 mm) 55,115~1,102,311 Lb/hr (5,000~500,000 kg/hr)	150										
8" (200 mm) 110,231~2,204,623 Lb/hr (50,000~1,000,000 kg/hr)	200										
10" (250 mm) 165,346~3,306,900 Lb/hr (75,000~1,500,000 kg/hr)	250										
12" (300 mm) 2,204,623~5,511,556 Lb/hr (100,000~2,500,000 kg/hr)	300										
150# ANSI Flange	F										Process Connections
300# ANSI Flange	F3										
Other	O										
0.1%		1									Accuracy
0.2%		2									
0.5%		5									
-58°F-257°F (-50°C-125°C) max - Standard			1								Temperature Rating
-58°F-392°F (-50°C-200°C) max - Remote Display Only			2								
-58°F-662°F (-50°C-350°C) max - Remote Display Only			3								
232 psig (1.6 MPa) - Standard				1							Pressure Rating
362 psig (2.5 MPa)				2							
580 psig (4.0 MPa)				3							
Other pressure (Please contact factory)				O							
TSY Compact Version - surface touch control, display, 4-20mA, RS485							CYS				Transmitter
TSY Compact Version - surface touch control, display, 4-20mA, RS485, HART							CYH				
TSY Remote Version - surface touch control, display, 4-20mA, RS485							RYS				
TSY Remote Version - surface touch control, display, 4-20mA, RS485, HART							RYH				
Non-Explosion								NX			Approval
Exdib II CT3~T6 for transducer, Exd[iib] II CT6 transmitter (for remote)								XI			
Exdib II CT4~T6 (for compact)								XD			
85~260 V _{AC}									AC		Power Supply
24 V _{DC}									DC		
Standard SS #316L measuring tube										NN	Options
Extra signal cable for remote type transmitters (per meter length)										CBL	
Heat Jacket										HJ	

