



ALOVPD

Positive Displacement Flowmeters

Series ALOVPD Meters

GENERAL

The SmartMeasurement ALOVPD Oval gear flowmeter features two precisely machined rotating elliptical (oval) gears which rotate and mesh within the meter's interior housing in order to form a measuring chamber of known volume. The ALOVPD may be used to accurately determine volumetric flow rate as a function of the gears' velocity. The design of the oval gear meter makes it an ideal choice for applications where a higher priced PD meter may be too expensive for certain non critical applications. The low cost ALOVPD provides good accuracy while offering reduced pressure drop versus traditional circular-gear type PD meters. The ALOVPD meter comes with a rugged battery-powered display module that indicates flow rate and totalized flows in user-configurable engineering units.



FEATURES

- Superior accuracy - to 0.5% of reading with $\pm 0.03\%$ repeatability
- Elliptical gear design provides low pressure loss
- Meter body is available in Cast Iron (Std), CS, SS# 304 or SS# 316
- Bearings are available in Cast Iron (Std), CS, SS# 304 or SS# 316
- Will accommodate pressures of up to 915 psig (63 bar)
- Will accommodate viscosities of up to 2000 cP

SPECIFICATIONS

- | | | | |
|------------------------|---|------------------------|---|
| • Flow range: | up to 1500 GPM (340 M ³ /hr) | • Ambient temperature: | -30 up to +70°C |
| • Line size : | ¼" ~ 8" (8-200mm) | • Supply Voltage UB: | +24 V _{DC} controlled |
| • Operating pressure: | up to 915 psig (63 bar) | • Output: | pulse, 4-20 mA or RS485 |
| • Process temperature: | up to 392°F (200°C) | • Display: | rate, total, low flow cut-off, battery consumption |
| • Body Material: | Cast Iron (Std) Carbon Steel, SS# 304, or SS# 316 | • User parameters: | K-factors, linear correction coefficient flow rate, input signal, section points, temperature |
| • Viscosity: | up to 2,000 CP | • Housing: | IP 67, aluminum AlMgSiPb, blue anodized |
| • Enclosure rating: | NEMA 4X (IP 65) 67 | • Ex-protection: | II 2 G EEx ia IIC T4 |
| • Accuracy: | $\pm 0.5\%$ (Std), $\pm 0.2\%$ (Opt) of reading | | |
| • Repeatability: | $\pm 0.03\%$ of reading | | |
| • Frequency range : | 1 up to 30,000 Hz | | |
| • Working Humidity: | <90% @ 75 °F | | |

■ ALOVPD Flow range in M³/Hr

Pipe Size (in mm)	viscosity (in cP)								Pulse (Liter per Pulse)
	0.3-0.8	0.8-2		2-200		200-1000		1000-2000	
	Gasoline	Kerosene		Light diesel		Crude oil		Heavy oil	
Accuracy	0.50%	0.50%	0.20%	0.50%	0.20%	0.50%	0.20%	0.50%	
¼" (8)	0.08~0.25	0.05~0.25	0.1~0.25	0.05~0.25	0.08~0.25	0.02~0.05	0.03~0.05	/	0.00171
⅜" (10)	0.2~0.5	0.08~0.5	0.15~0.5	0.05~0.5	0.08~0.5	0.03~0.3	0.06~0.3	0.03~0.2	0.00171
½" (15)	0.5~1.5	0.3~1.5	0.5~1.5	0.15~1.5	0.3~1.5	0.1~1.05	0.2~1.05	0.07~0.75	0.00598
¾" (20)	1.5~3	0.5~3	1~3	0.3~3	0.5~3	0.2~2.1	0.4~2.1	0.15~1.5	0.01218
1" (25)	3~6	1~6	2~6	0.6~6	1~6	0.4~4.2	0.8~4.2	0.3~3	0.011936
1¼" (32)	7.5~15	2.5~15	5~15	1.5~15	2.5~15	1.0~10.5	1.0~10.5	0.7~7.5	0.027092
1½" (40)	6~20	4~20	6~20	2~20	4~20	1.6~16.8	3.2~16.8	1.2~12	0.03306
2" (50)	8~24	4.8~24	8~24	2.4~24	4.8~24	1.4~14	2.8~14	1.0~10	0.024
2½" (65)	20~40	8~40	15~40	4~40	8~40	2.8~28	5.6~28	2~20	0.0547
3" (80)	30~60	12~60	20~60	6~60	12~60	4.2~42	8.4~42	3~30	0.1224
4" (100)	50~100	20~100	34~100	10~100	20~100	6~70	12~70	5~50	0.26178
6" (150)	95~190	38~190	64~190	19~190	38~190	13.3~133	26.6~133	9.5~95	0.31476
8" (200)	170~340	56~340	114~340	34~340	56~340	23.8~238	47.6~238	17~170	0.31538

* Special flow range inquiry, please contact factory

■ Electronic Counter



Standard: Pulse
4-20mA
Option: HART

■ Mechanical counter (option J)



Standard: Pulse
Option: 4-20mA



■ Smith meter Mechanical counter (option M)



■ Analog output (Pulse or 4-20mA) generator



■ Pressure Drop

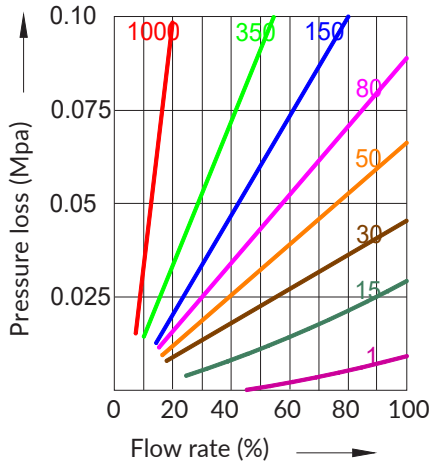

■ Accuracy Error

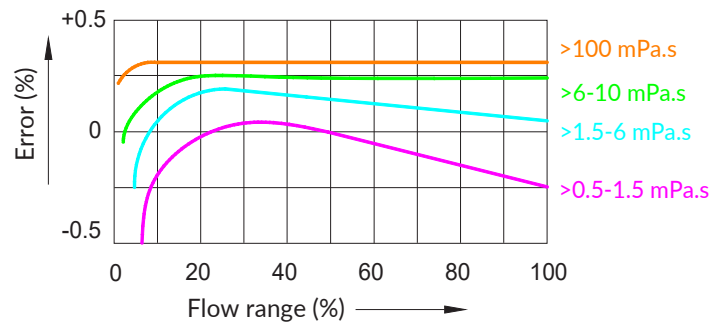

■ ALOVPD dimensions with the mechanical counter

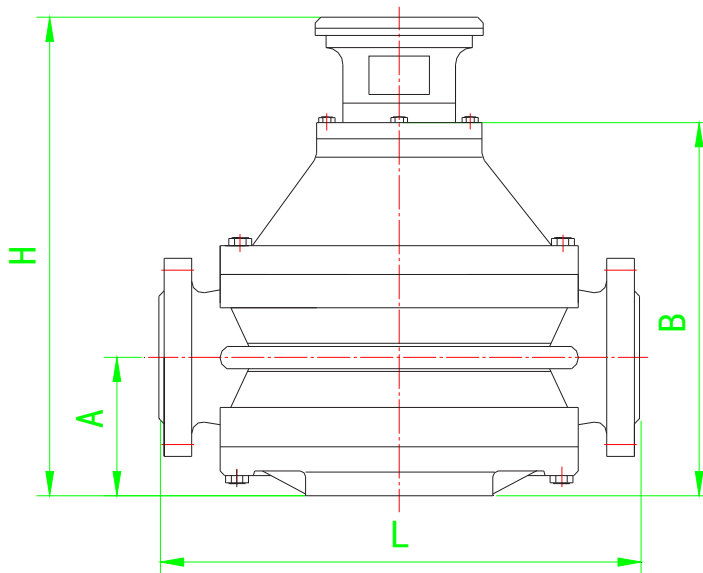

Meter Size	Flanges Distance L (mm)			Total Height H (mm)			Flow body Height B (mm)			Center Height A (mm)			Weight (kg)		
	Iron	CS	304	Iron	CS	304	Iron	CS	304	Iron	CS	304	Iron	CS	304
DN8	150	/	170	213	/	216	135	/	133	45	/	45	6	/	7
DN15	170	200	200	226	220	226	147	145	142	48	53	48	8	12	11
DN25	260	300	280	246	255	249	164	175	171	60	68	64	18	22	21
DN40	245	310	265	271	285	350	199	205	183	77	83	92	20	27	24
DN50	340	384	270	379	400	350	249	270	183	88	88	92	46	66	24
DN80	420	450	420	441	460	500	311	330	370	118	118	153	87	118	82
DN100	515	505	515	467	485	554	337	355	405	131	131	181	160	210	127
DN150	540	540	540	565	565	607	435	435	455	210	210	210	245	260	280
DN200	650	650	650	624	625	646	494	495	494	247	247	247	400	430	435

* DN8mm is thread connection type, * Nominal pressure is <6.4MPa.

* For DIN flange. Special dimension inquiry, please contact factory.

Please contact your local SmartMeasurement application engineer
 You also need to provide the following information:

FLUID INFORMATIONS	We need the name of your fluid media, operating density, viscosity, pressure and temperature.
FULL SCALE FLOW (MAX/MIN FLOW)	Indicate maximum and minimum flow rates, units must be Kg/hr, Lb/hr, LPM or gpm, etc..
LINE SIZE	We need to know your pipe size as well connection type (flange, threaded, etc..)
ALLOWABLE PRESSURE DROP	Allowable pressure drop (see graph below) that your process can withstand
TYPE OF ELECTRONICS	Indicate if you want integral, remote panel or remote wall mounted
POWER REQUIREMENTS	Specify your power requirements such as 12 V _{DC} or 24 V _{DC}

ALOVPD SERIES

EXAMPLE ALOVPD-50-J-1.6-G-A-NN

ALOVPD		**	**	**	**	**	**	**	**	DESCRIPTION
Nominal Dia: ¼"	008									Line size
Nominal Dia: ½"	015									
Nominal Dia: 1"	025									
Nominal Dia: 1 ½"	040									
Nominal Dia: 2"	050									
Nominal Dia: 3"	080									
Nominal Dia: 4"	100									
Nominal Dia: 6"	150									
Nominal Dia: 8"	200									
Nominal Dia: 10"	250									
Electronic transmitter with display and output	D									Transmitter type
Round mechanical counter	J									
Smith mechanical counter	M									
Analog outputs Pulse or 4-20mA	T									
232 psi (1.6 Mpa)	1.6									Operating Pressure
362 psi (2.5 Mpa)	2.5									
580 psi (4.0 Mpa)	4.0									
928 psi (6.4 Mpa)	6.4									
Cast Iron gear & housing. Up to 16 bar, only for DIN PN16	G									Gear & casing material
Cast steel gear & housing	CS									
SS# 304 housing and gear	304									
SS# 316 housing and gear	316									
Other option	**									
Working temperature:-4°F ~ +140°F (-20°C ~ +60°C)	A									Application temperature
Working temperature up to +390°F (+200°C)	B									
Normal viscosity < 200 cP	N									Fluid viscosity
High viscosity >200 cP	H									
Exd proof	EX									Options
Extra output for mechanical counters - Pulse	FP									
Extra analog output for mechanical counters - 4-20mA	FI									
Special fluid: gasoline or liquid gas	SF									
Heat Jacket (steam or oil)	HJ									
Filter	FT									
Other Options	**									

