



ALVT

Vortex Flowmeter

ALVT Series

GENERAL

Vortex flow sensing technology relies on measuring the number of vortex pulses generated by a bluff body immersed in the flow stream. The vortex meter uses dual sensor technology, producing two independent vortex signals which allows for signal amplification and common mode noise reduction. Our sensors never touch the process fluid; the crystal sensors are bonded behind a stainless steel wall. The electronics pick up the slightest pressure pulsations generated by the vortices through the stainless steel wall. This design allows meters to have an extremely wide turndown while maintaining an almost unlimited upper end and a high pressure rating.

FEATURES

- Suitable for a wide variety of applications having steam, gas, or liquid medias
- No moving parts and no leak paths; no o-ring or graph oil seals to wear, fail or leak
- Two independent sensors, allowing for better signal amplification and noise reduction
- Error messages displayed for erratic flows and flows outside of calibrated ranges
- Field calibration possible with integral or remote electronics and keypad
- True 2-wire 4-20 mA interface
- Wide measuring range, turn-down ratio of 10:1
- Available as an integrated mass flow vortex
- Area of measurement can be smaller than pipe connection for better rangeability



SPECIFICATION

• Process Connections:	Wafer (standard), Flanged	• Housing protection:	IP65; IP67
• Process temperature:	-20~+180°F (-5~+250°C) (with LCD display)	• Cable:	10 m free for remote version
• Operating pressure:	232 psig (1.6MPa) standard; up to (428 psig) 6.4 MPa optional	• weight (approximate):	Wafer: 22~29 lbs (10 ~ 13kg) to 12" (DN300) Flange: Flange weight contact factory
• Velocity Range:	Depends on fluid, pressure and temperature	• Signal Interface:	RS485, HART
• Liquids:	2~20 ft/s (0.6~6 m/s)	• Display units:	m³/h, kg/hr
• Gas & Steam:	23~148 ft/s (5~65 m/s)	• Keypad:	Rate, Total
• Accuracy	1.0% for liquid, 1.5% for gas and steam	• Power supply:	110/220 VAC or isolated 14~36 VDC
• Repeatability:	0.33% for liquid, 0.5% for gas	• NIST traceable:	Yes
• Turn down ratio	10:1	• Data storage:	EPROM storage up to 5 years
• Material:	Stainless Steel #304	• Data logger:	Reading, sampling times 0.5 S
• Signal output:	Pulse output, 2-wire 4~20mA DC, VDC, RS485, Hart, ModBus		
• RAM Back-up	Lithium Battery, 3.6VDC		

■ Flange

DN	L ± 3		H ± 3		Weight (kg)	
	class	class	class	class	class	class
	150#	300#	150#	300#	150#	300#
25	180	180	390	390	4.68	5.68
32	180	180	390	390	5.42	6.82
40	180	180	400	400	5.97	8.36
50	180	200	400	400	7.58	8.84
65	200	200	400	410	10.4	11.96
80	200	200	415	435	12.39	15.75
100	220	220	430	457.5	17.24	23.89
125	220	220	430	481.5	19.29	30.63
150	220	220	505	522	24.82	39.91
200	220	220	550	579.5	35.73	58.79
250	250	250	590	632	51.93	85.16
300	300	300	630	694.5	76.1	122.4

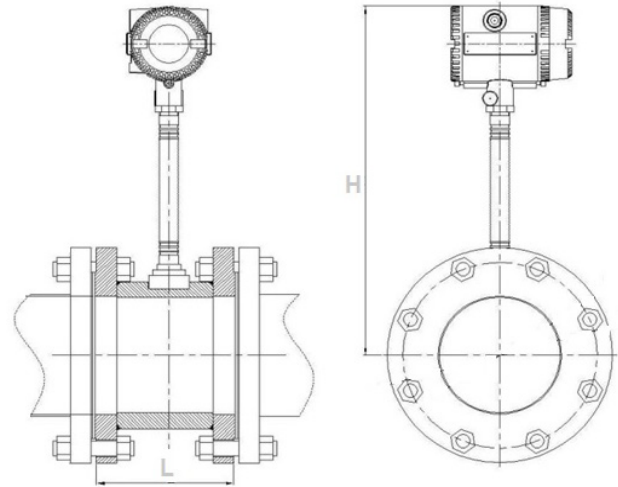

■ Wafer

DN	L ± 3	D ± 3	K ± 3	H ± 3	Weight
15	65	75	130	331	4.01kg
20				328.5	3.90kg
25				326	3.76kg
32	70	80	145	332.8	4.11kg
40				337.8	4.35kg
50	75	94	160	348	4.77kg
65		105	180	361	5.09kg
80	84	120	192	376	6.19kg
100	90	140	230	397	7.61kg
125	100	165	242	423	9.89kg
150	120	190	280	448	13.44kg
200	150	240	335	501	21.89kg
250	160	290	405	549	30.51kg
300	170	340	460	599	40.85kg

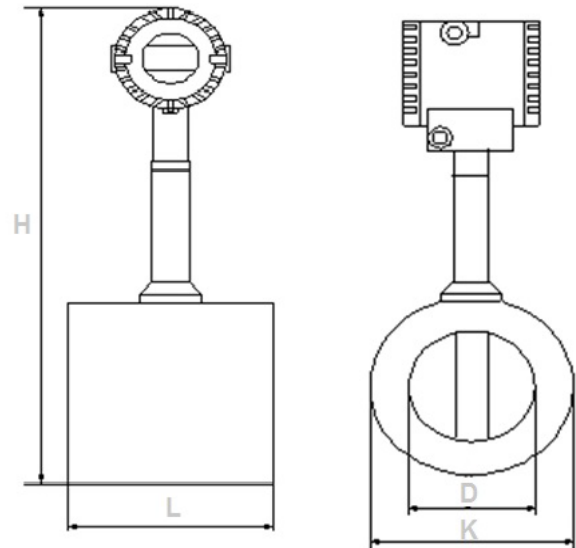

■ Mass flow of saturated steam (kg/hr)

Pressure	0.3Mpa		0.4Mpa		0.6Mpa		0.7Mpa		0.8Mpa		1Mpa		1.2Mpa		1.5Mpa	
Temp	133.5deg C		143.6deg C		158.9deg C		165deg C		170.7deg C		179.88deg C		187.96deg C		198.4deg C	
Density	1.615Kg/m ³		2.163Kg/m ³		3.17Kg/m ³		3.667Kg/m ³		4.162Kg/m ³		5.147Kg/m ³		6.127Kg/m ³		7.602Kg/m ³	
DN15	11	63	12	73	14	88	15	85	16	101	18	112	19	123	23	136
DN20	13	102	15	116	18	141	19	151	20	161	22	179	24	196	27	218
DN25	17	133	19	153	23	185	25	199	27	212	30	236	32	257	36	287
DN32	30	236	34	271	41	328	44	352	47	375	52	417	57	455	63	507
DN40	34	340	39	390	47	470	51	510	54	540	60	600	66	660	73	730
DN50	63	630	73	730	88	880	95	950	101	1,010	112	1,120	122	1,220	136	1,360
DN65	106	1,060	121	1,210	146	1,460	158	1,580	168	1,680	187	1,870	204	2,040	227	2,270
DN80	148	1,480	170	1,700	205	2,050	221	2,210	235	2,350	262	2,620	285	2,850	318	3,180
DN100	222	2,220	242	2,420	293	2,930	315	3,150	336	3,360	374	3,740	408	4,080	454	4,540
DN125	318	3,180	363	3,630	440	4,400	473	4,730	504	5,040	561	5,610	612	6,120	681	6,810
DN150	423	4,230	484	4,840	586	5,860	631	6,310	672	6,720	747	7,470	815	8,150	908	9,080
DN200	847	8,470	969	96,900	1,173	11,730	1,262	12,620	1,344	13,440	1,495	14,950	1,631	16,310	1,815	18,150
DN250	1,270	12,700	1,453	14,530	1,769	17,690	1,892	18,920	2,016	20,160	2,242	22,420	2,446	24,460	2,725	27,250
DN300	2,116	2,160	2,422	24,220	2,932	29,320	3,154	31,540	3,360	33,600	3,737	37,370	4,077	40,770	4,541	45,410

*Note: The pressure in table is gauge pressure

■ Mass flow of superheated steam (kg/hr)

ID (mm)	min flow		max flow	
15	8.24	$\sqrt{\rho}$	49.5	$\sqrt{\rho}$
20	9.88	$\sqrt{\rho}$	79	$\sqrt{\rho}$
25	13.12	$\sqrt{\rho}$	104	$\sqrt{\rho}$
32	23	$\sqrt{\rho}$	184	$\sqrt{\rho}$
40	26.65	$\sqrt{\rho}$	265	$\sqrt{\rho}$
50	49.41	$\sqrt{\rho}$	494	$\sqrt{\rho}$
65	82.35	$\sqrt{\rho}$	585	$\sqrt{\rho}$
80	115.3	$\sqrt{\rho}$	823	$\sqrt{\rho}$
100	164.7	$\sqrt{\rho}$	1,153	$\sqrt{\rho}$
125	247.1	$\sqrt{\rho}$	1,647	$\sqrt{\rho}$
150	329.4	$\sqrt{\rho}$	2,471	$\sqrt{\rho}$
200	658.8	$\sqrt{\rho}$	3,294	$\sqrt{\rho}$
250	988.2	$\sqrt{\rho}$	6,588	$\sqrt{\rho}$
300	1,647	$\sqrt{\rho}$	9,882	$\sqrt{\rho}$

*Note: ρ ---density of the superheat steam under operating condition (Kg/m³)

■ Volumetric flow of gas (N m³/hr)

ID (mm)	Flow range	Frequency- Hz
15	5-30	460-3700
20	6-50	220-3400
25	8-60	180-2700
32	14-100	130-1400
40	18-180	90-1550
50	30-300	80-1280
65	50-500	60-900
80	70-700	40-700
100	100-1000	30-570
125	150-1500	23-490
150	200-2000	18-360
200	400-4000	13-325
250	600-6000	11-220
300	1000-10000	9-210

*Note: Standard condition 20°C, 0.1MPa (absolute pressure), or under atmosphere at 20°C

■ Volumetric flow of liquid (m³/hr)

ID (mm)	Flow range	Frequency- Hz
15	1.5-6	90-900
20	1.2-8	40-600
25	2-16	35-400
32	2.2-20	20-250
40	2.5-25	10-240
50	3.5-35	8-190
65	6-60	7-150
80	13-130	6-110
100	2-200	5-90
125	30-300	4.5-76
150	50-500	3.8-60
200	100-1000	3.2-48
250	150-1500	2.5-37.5
300	200-2000	2.2-30.6

Please contact your local SmartMeasurement application engineer
 You also need to provide the following information:

TYPE OF FLUID (LIQUID/GAS OR STEAM)
FULL SCALE FLOW
LINE SIZE
PROCESS PRESSURE AND TEMPERATURE
TYPE OF ELECTRONICS
POWER REQUIREMENTS

Please provide the name of your fluid, including operating density and viscosity

Maximum and minimum flow rates, units must be Kg/hr, Lb/hr, LPM or GPM

Please specify your pipe size as well connection type (flange, threaded)

We will calibrate your meter as close to your operating conditions as possible

Please indicate if you want integral or remote electronics

Please specify your power requirements such as 24 V_{DC}, 115 V_{AC} or 230 V_{AC}

ALVT										
EXAMPLE:ALVT-2-3-40-D-1-2-0-N-1-NNN										
ALVT		**	**	**						DESCRIPTION
Flanged	1									Style
Wafer	2									
Liquid	2									Fluid
Gas	3									
Steam	4									
Inline type DN15~DN300 (½"~12")			**							Line Size
Integral with digital display - standard					D					Display
Remote with 5m cable					R					Display
13.5~45 V _{DC} - Standard					1					Power Supply
3.6V lithium battery -no outputs					2					
13.5~45 V _{DC} + lithium battery					3					
No output					0					Signal Output
Pulse output					1					
Two wire 4-20mA DC output					2					
No communication					0					Communication
RS-485 Communication without 4-20mA					3					
Hart Communication @ 4-20mA					5					
Standard -40~482 °F (-40 ~ 250 °C)					N					Temperature
High Temp 382~660 °F (250 ~350 °C)					H					
232 psi (1.6MPa)					1					Pressure
363 psi (2.5MPa)					2					
580 psi (4.0MPa)					3					
928 (6.4MPa)					4					
None							N			Explosion Proof
Explosive Isolated							G			
Intrinsically safe							B			
Intrinsically safety							B			
Standard material - SS #304							NN		Options	
Special material - SS #316							316			
Mass flow without PT100 and pressure transmitter							MS			
Mass flow with PT100 and pressure transmitter							MT			
Flow computer - 24 V _{DC} power, 4-20mA output, LED display							FC			

